

Chaotic motion

Chaotic motion (chaos, or deterministic chaos) is

- aperiodic motion
- sensitive dependence on initial conditions
 - in practice unpredictable at long times
- not completely random (phase space structure)
- often universal
 - different systems, similar transition to chaos

“Chaos theory” and nonlinear dynamics is a big field.

Here we will only discuss some of the basics

To have chaos in one dimension, we need

- dissipation (frictional forces)
- driving force (periodic)

Higher-dimensional chaos does not require damping & driving

The damped, driven pendulum

$$V(x) = mgl[1 - \cos(x)]$$

Harmonic oscillator for small- x motion;
here we will keep the full nonlinear $V(x)$

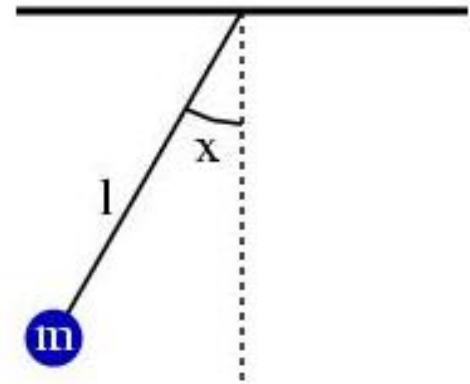

Adding driving and damping; the equation of motion is

$$\ddot{x}(t) = -k \sin(x) - \gamma v + Q \sin(\Omega t) \quad (m=1, k=gl)$$

This is a standard example illustrating chaotic motion

Also still actively studied in research (very rich behavior)!

Can be realized experimentally as well

We will discuss various ways to graphically analyze
[$x(t), v(t)$] data from numerical integration (“simulations”)

Phase space trajectories and attractors

No driving force ($Q=0$); pendulum comes to rest due to damping

$$k = 1, \gamma = 0.1$$

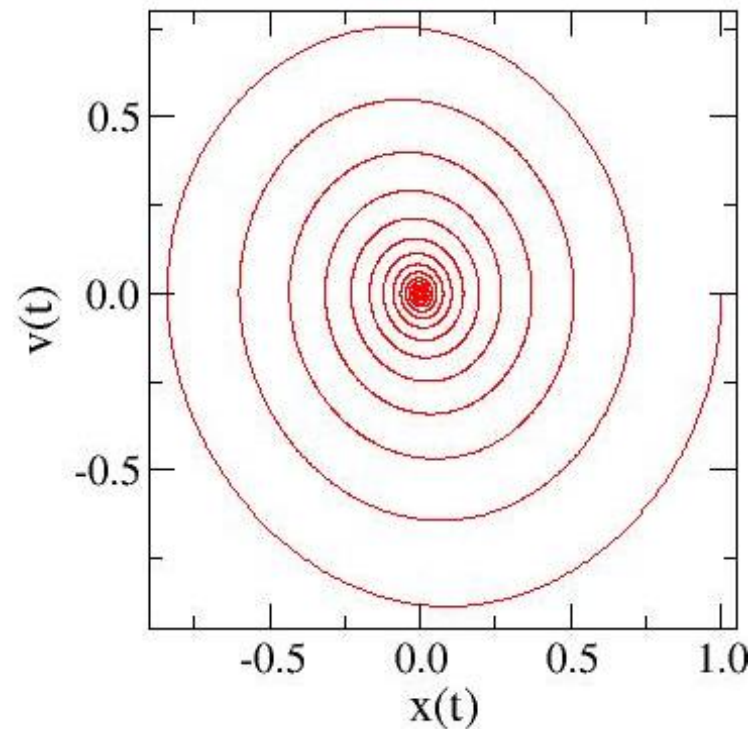
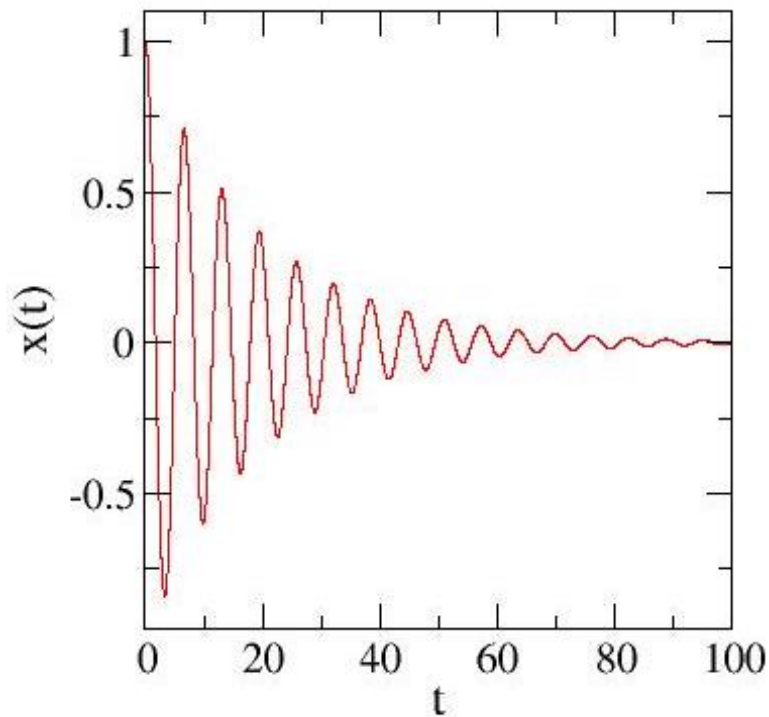

The point $(x=0, v=0)$ is the **attractor** of this motion

➤ approached for all initial conditions

Adding driving force

$$k = 1, \gamma = 0.1, \Omega = 2, Q = 1$$

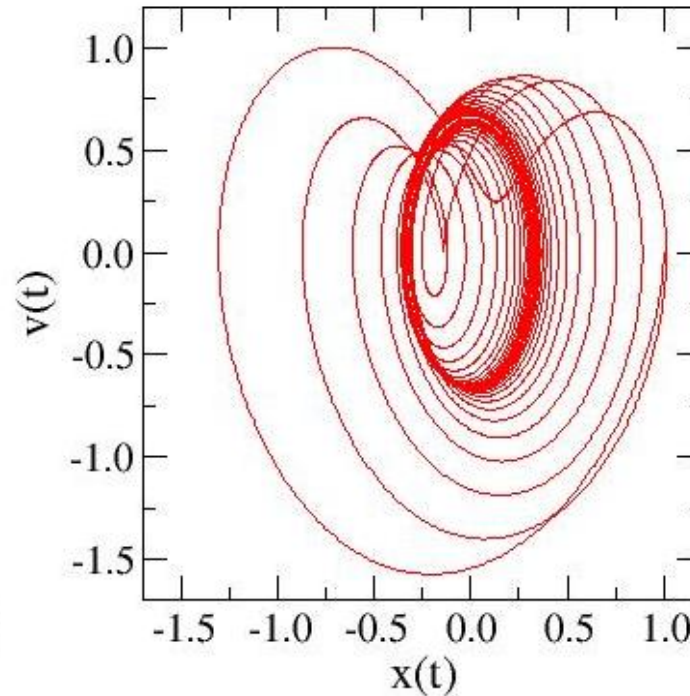
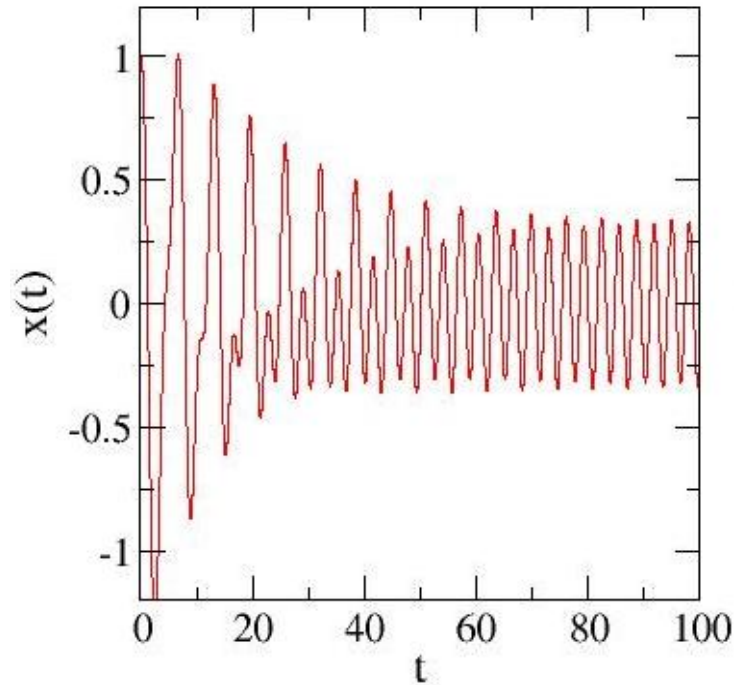

Initially; transient motion

Asymptotically; motion with period of the driving force

➤ The attractor is a loop in phase space

In general, there can be several attractors

➤ Space of initial conditions subdivide into **basins of attraction**

Period doublings

The period can be a multiple of that of the driving force

Sequences of period-doublings (bifurcations) can occur

Period = $2\pi/\Omega, 4\pi/\Omega, 8\pi/\Omega$

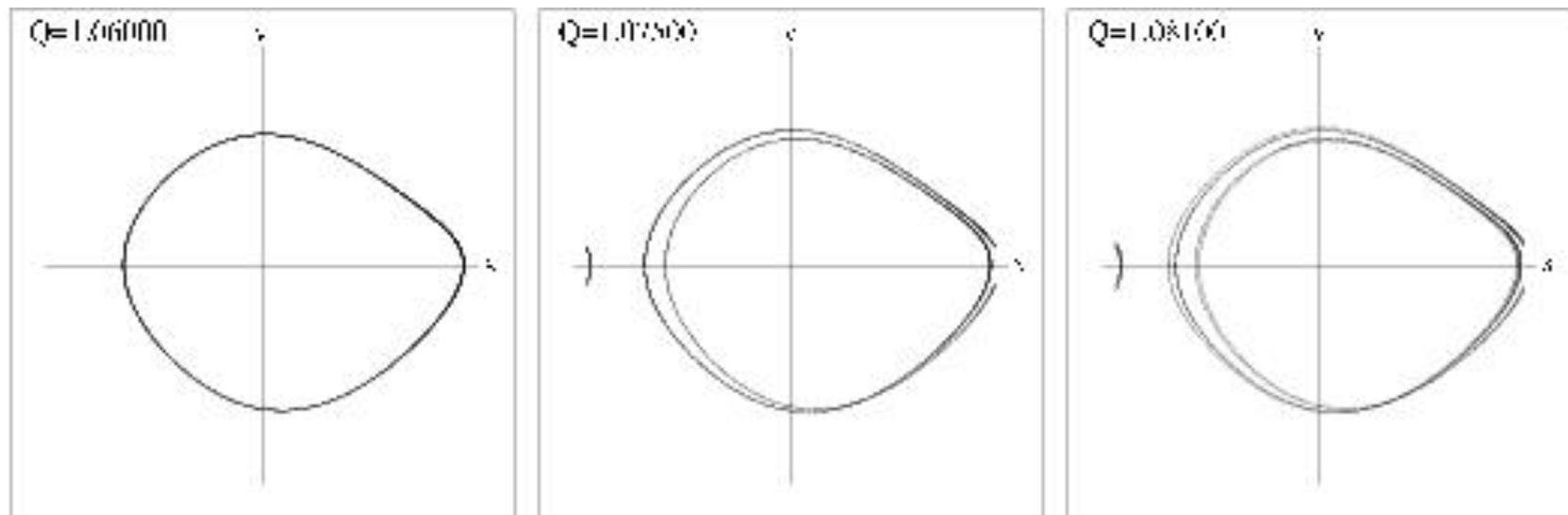

$$k = 1, \gamma = 1/2, \Omega = 2/3$$

More complex periodic attractors (limit cycles)

- Symmetry breaking; 2 attractors ($x \rightarrow -x, v \rightarrow -v$)
- Other attractors can exist as well

$Q=1.08$, different initial conditions

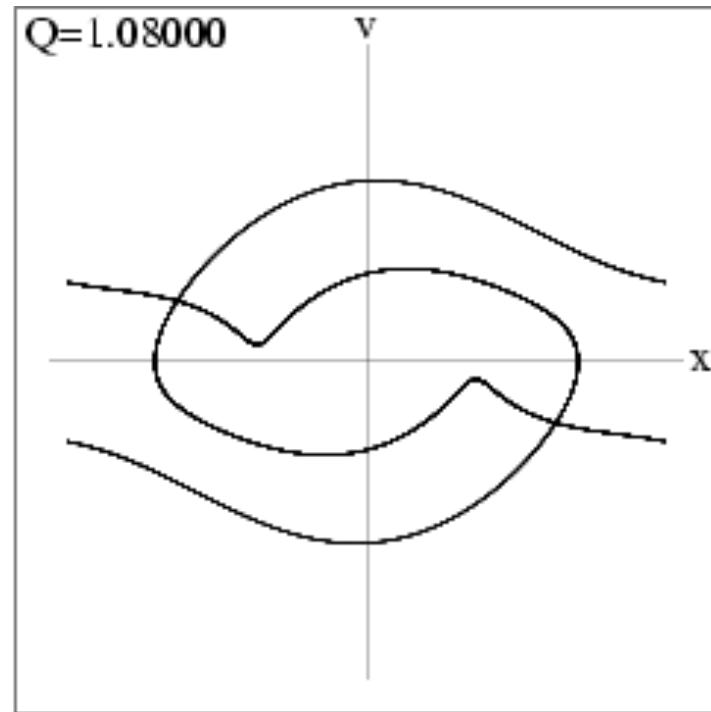
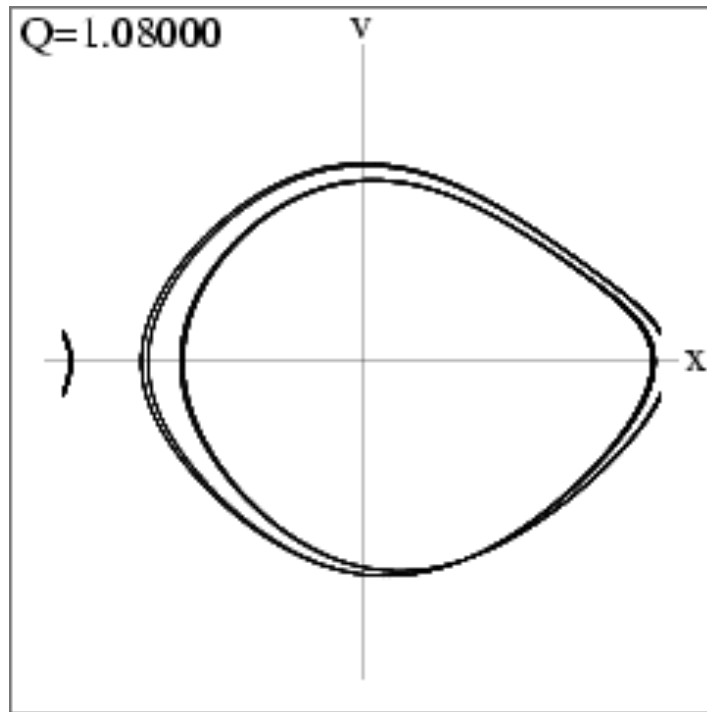

- 3 attractors \rightarrow 3 “basins of attraction” for this Q
- A basin of attraction is a region of the space of initial conditions that lead to a given attractor

Same initial conditions, different Q

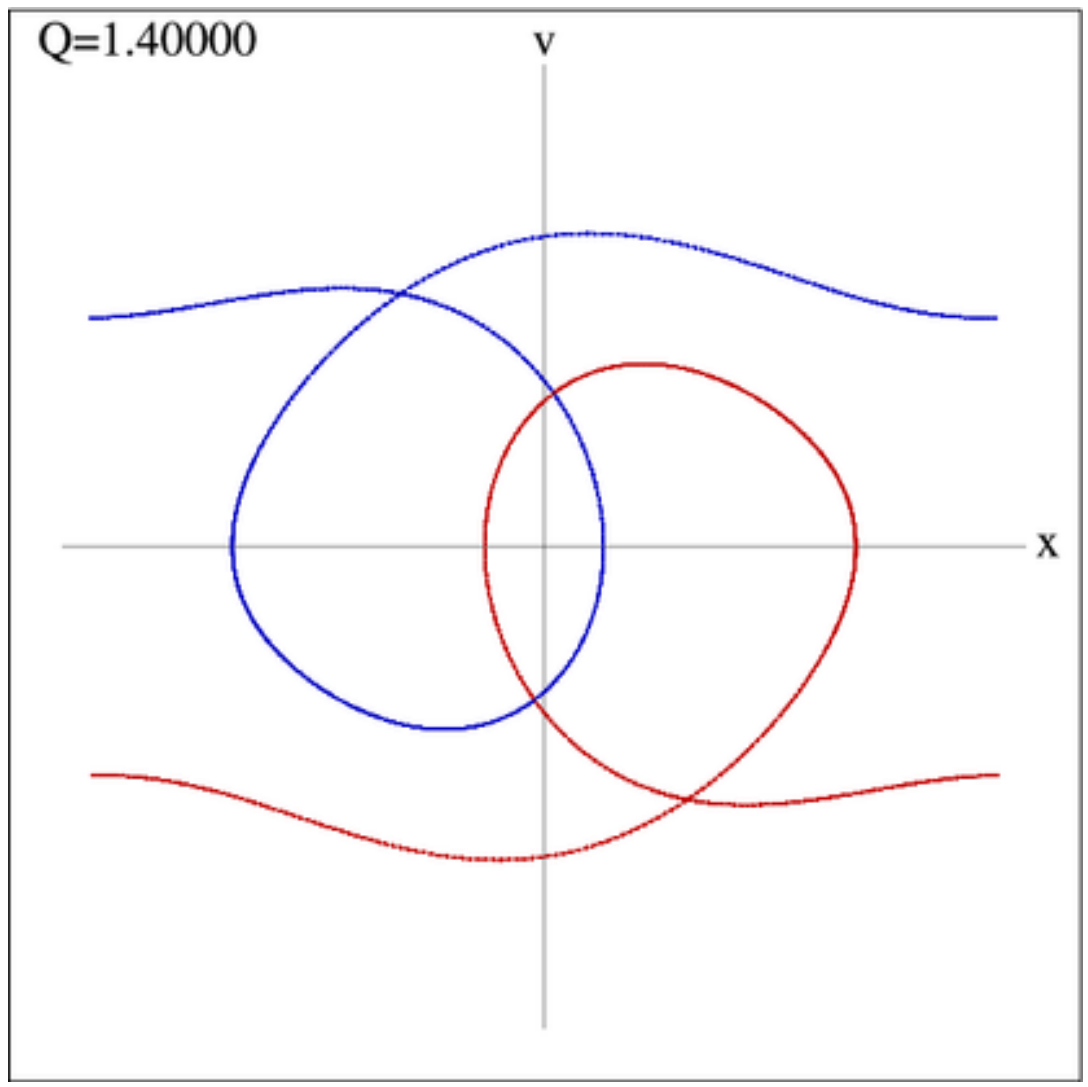

Poincare sections

Systematic studies of the phase space are easier using cuts through the phase space (surfaces in higher d).

E.g., plot velocity when x passes 0 (e.g., from left); can do vs Q

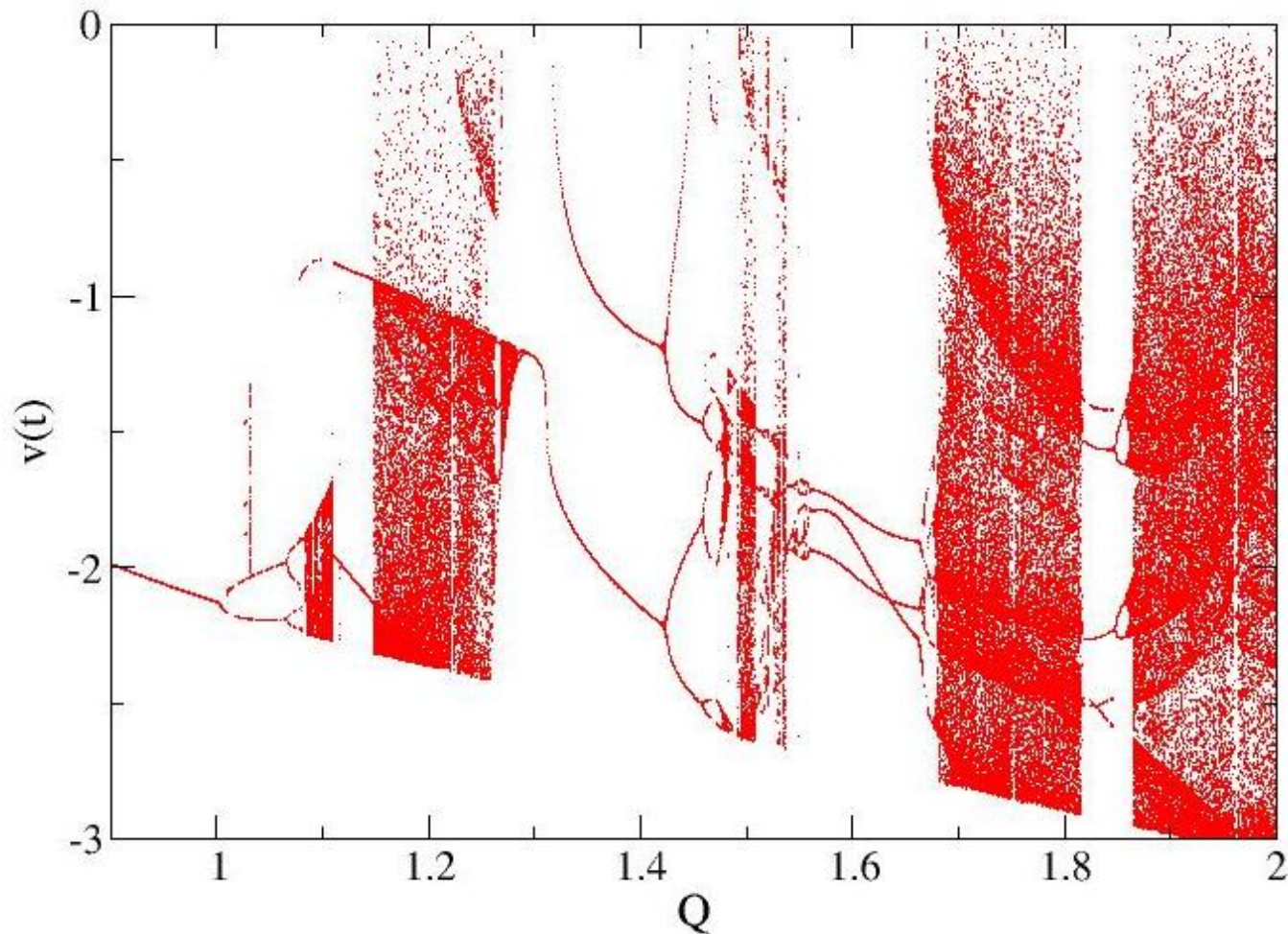

These plots are also called bifurcation diagrams

Blow-up of $Q=1.83-1.87$ region

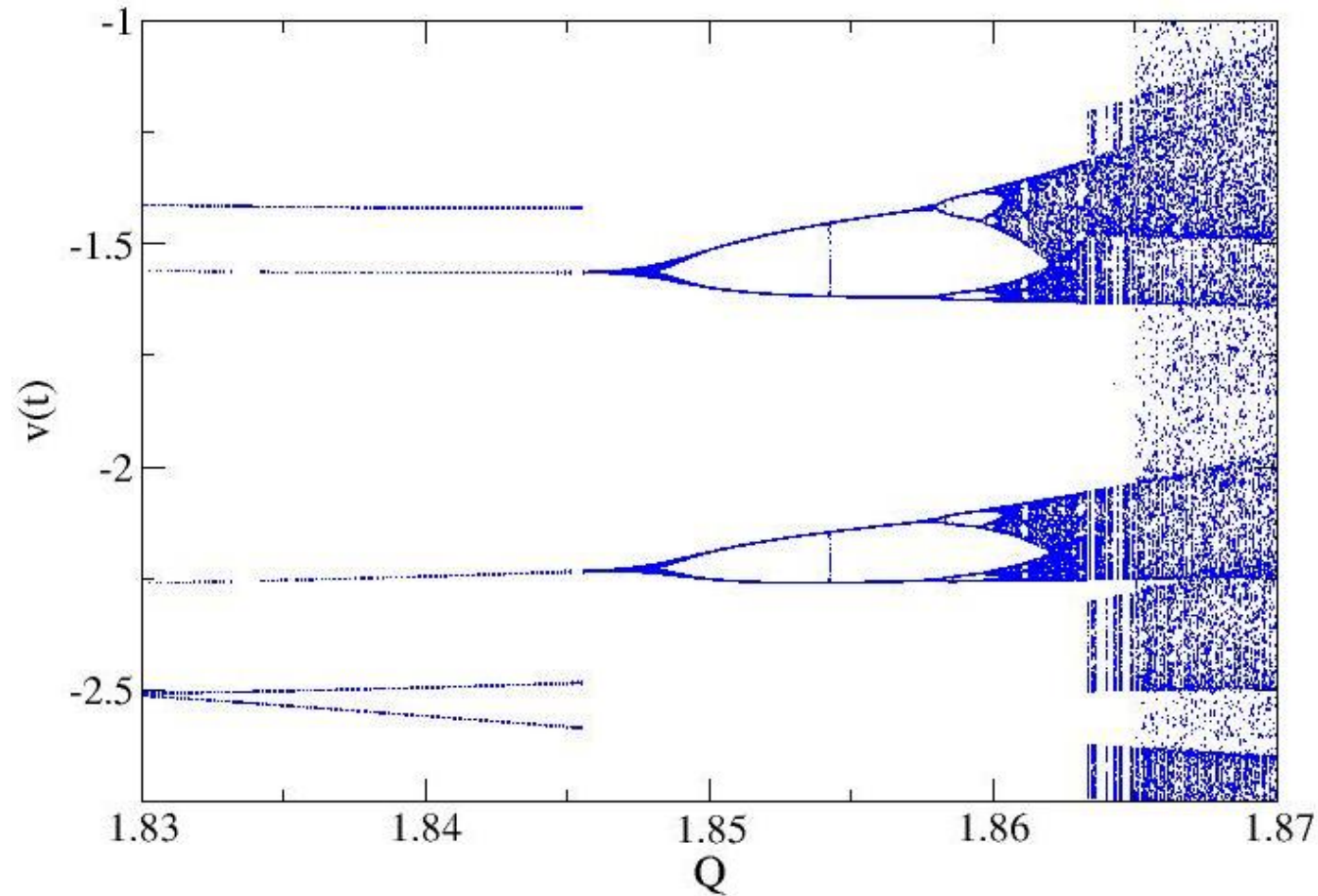

Universal transition to chaos

➤ Infinite series of period-doublings (bifurcations)

Period doubling bifurcations; logistic map

Universality at transition to chaos contained in

$$x_{n+1} = \mu x_n (1 - x_n)$$

Discrete index corresponds to points on Poincare section

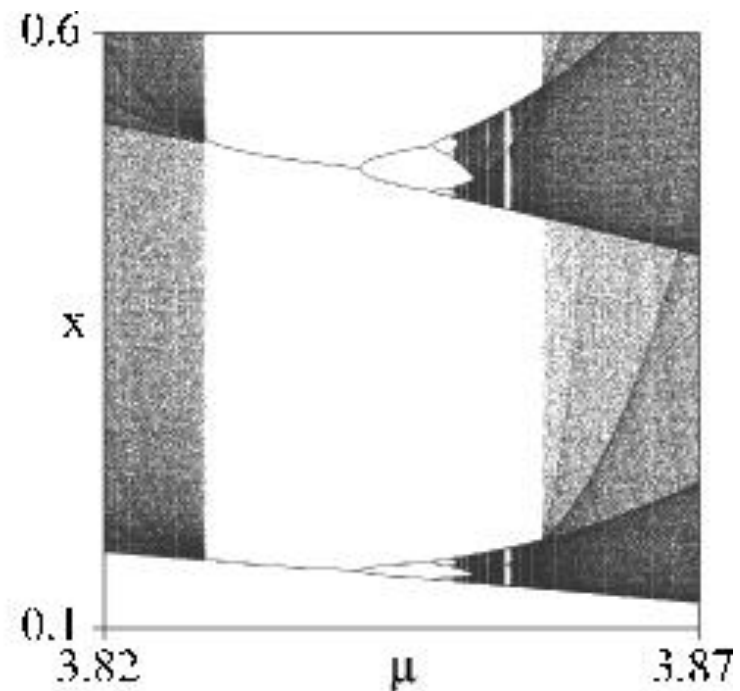
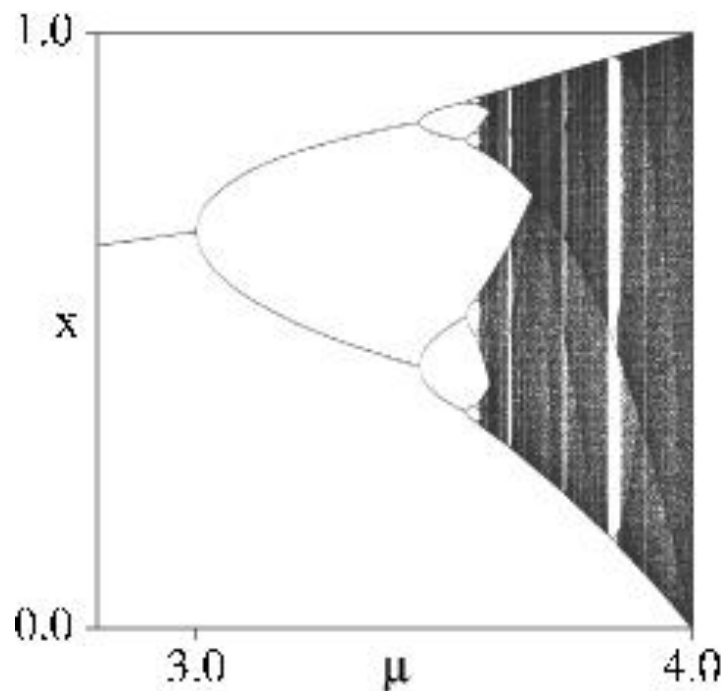

Period doublings in the pendulum (and other systems) can be exactly scaled to those in the logistic map (Feigenbaum).

There are also other “routes to chaos”

Phase-space attractor in the chaotic regime

- no periodicity; can be fractal (strange attractor)

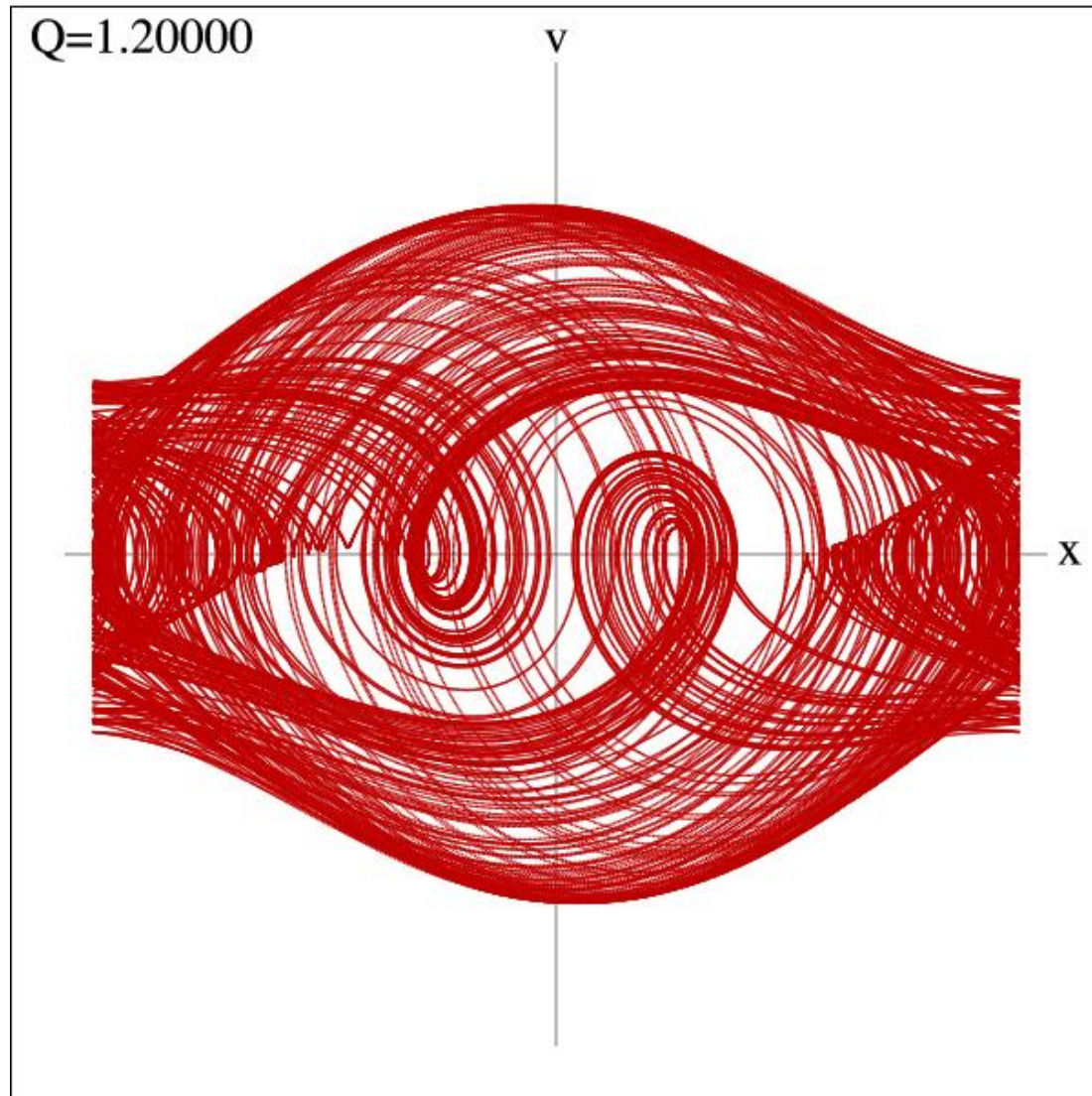

Stroboscopic sampling

Other way to look at the phase space (also a type of Poincare section).

Plot $x(t), v(t)$ for t multiple of driving period: $t = n2\pi/\Omega$

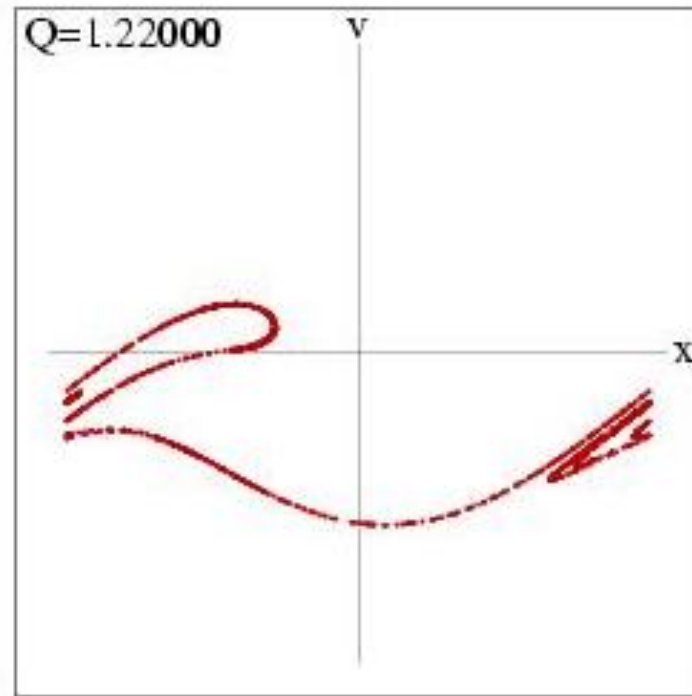
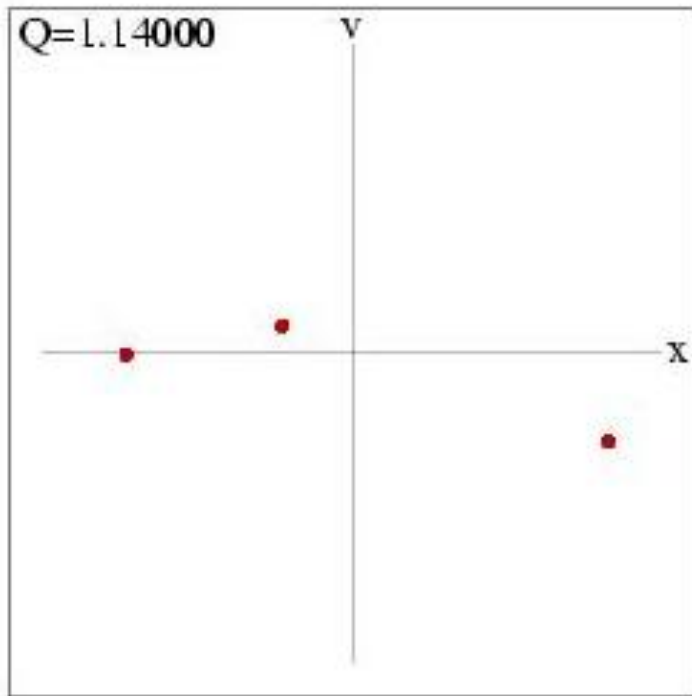

Strange attractor (fractal) for chaotic case

See programs on-line: `strobo1.f90` (writes data file)

`strobo2.f90` (generates ps graph)