



Artificial Intelligence? Detecting & Diverting my Cat

ZIWEI HUANG
BOSTON UNIVERSITY
APRIL 29, 2021

Motivation:

- Where is my cat?
- How can I prevent my cat from entering undesired places?

Challenges:

- How to detect a cat?
- How to distinguish a cat from other creatures (human, dog, etc.)?



Key Components:

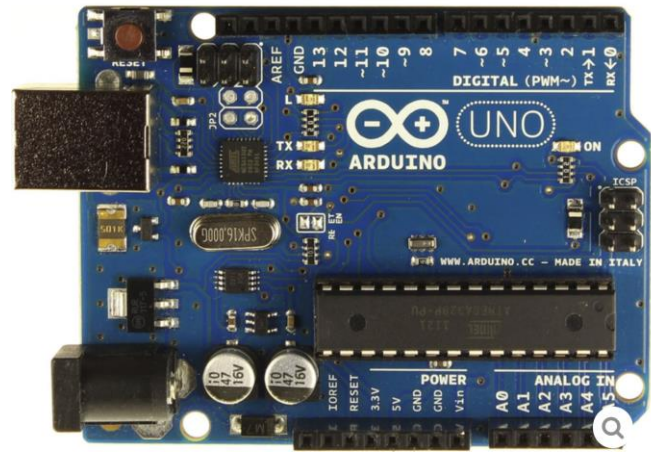

An extremely versatile microcontroller board

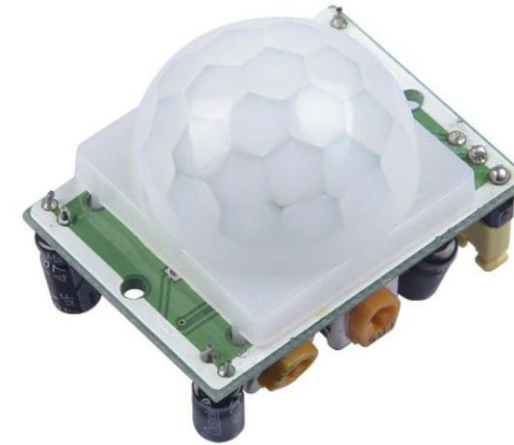

Passive Infrared Motion Sensor (PIR sensor) detect IR light radiation and moving object with heat.

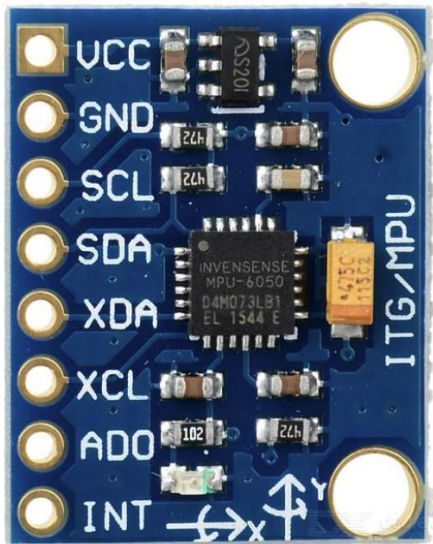

Inertia Measurement Unit is a Microelectromechanical system that measures mechanical perturbation



A cat wand is an interactive toys that is irresistible to in-door cats

Product Overview

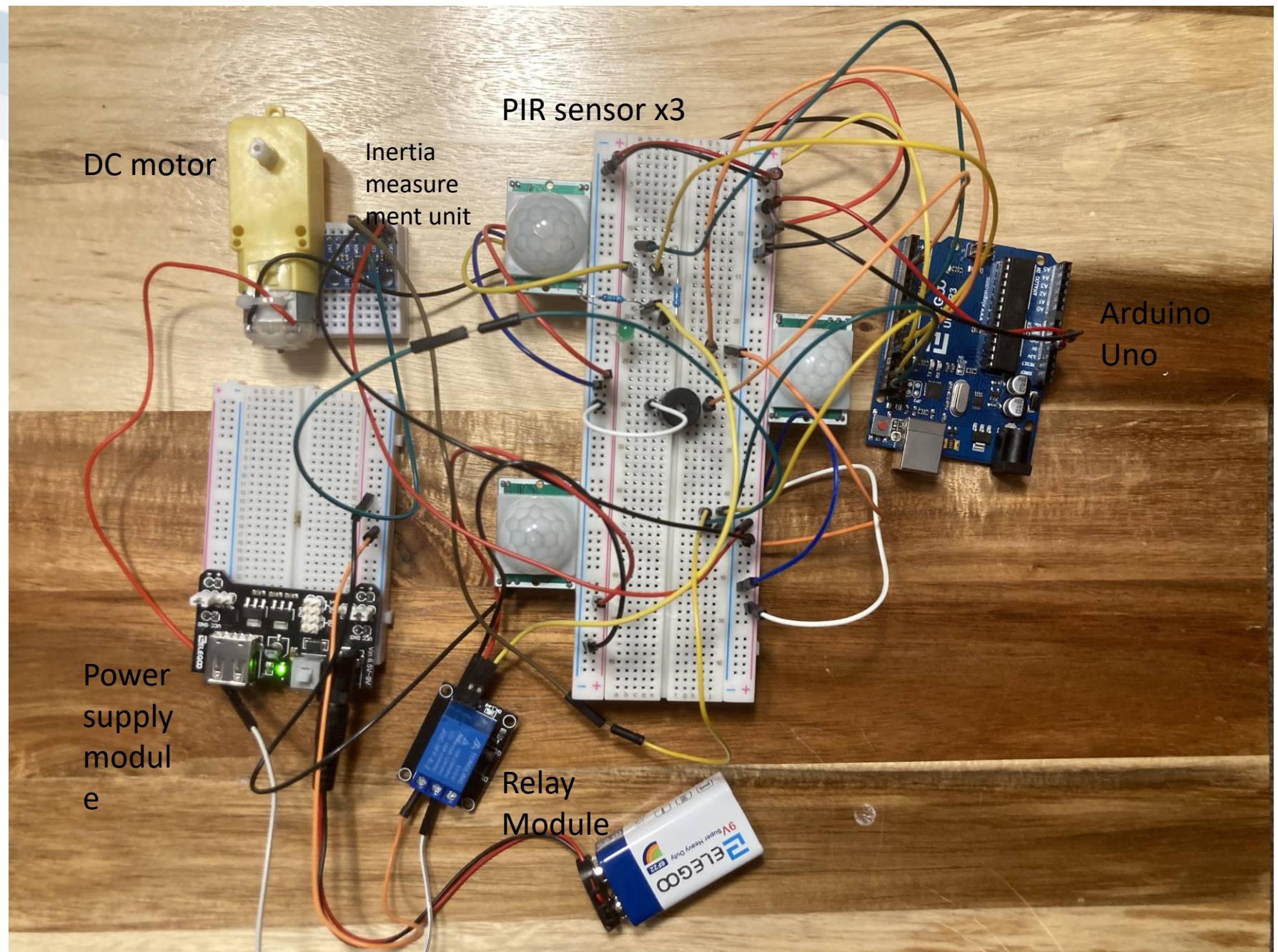

Flow Chart

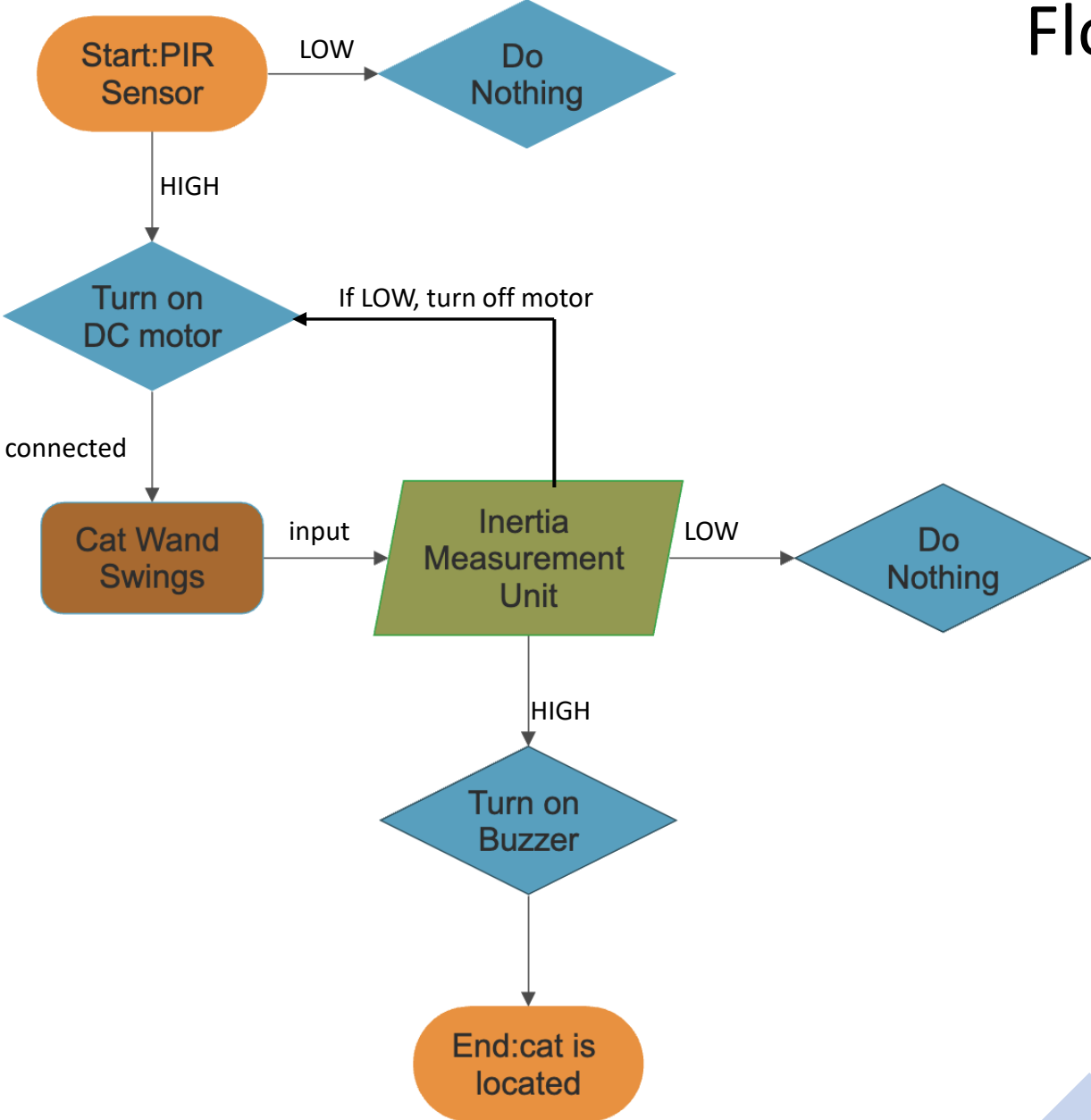

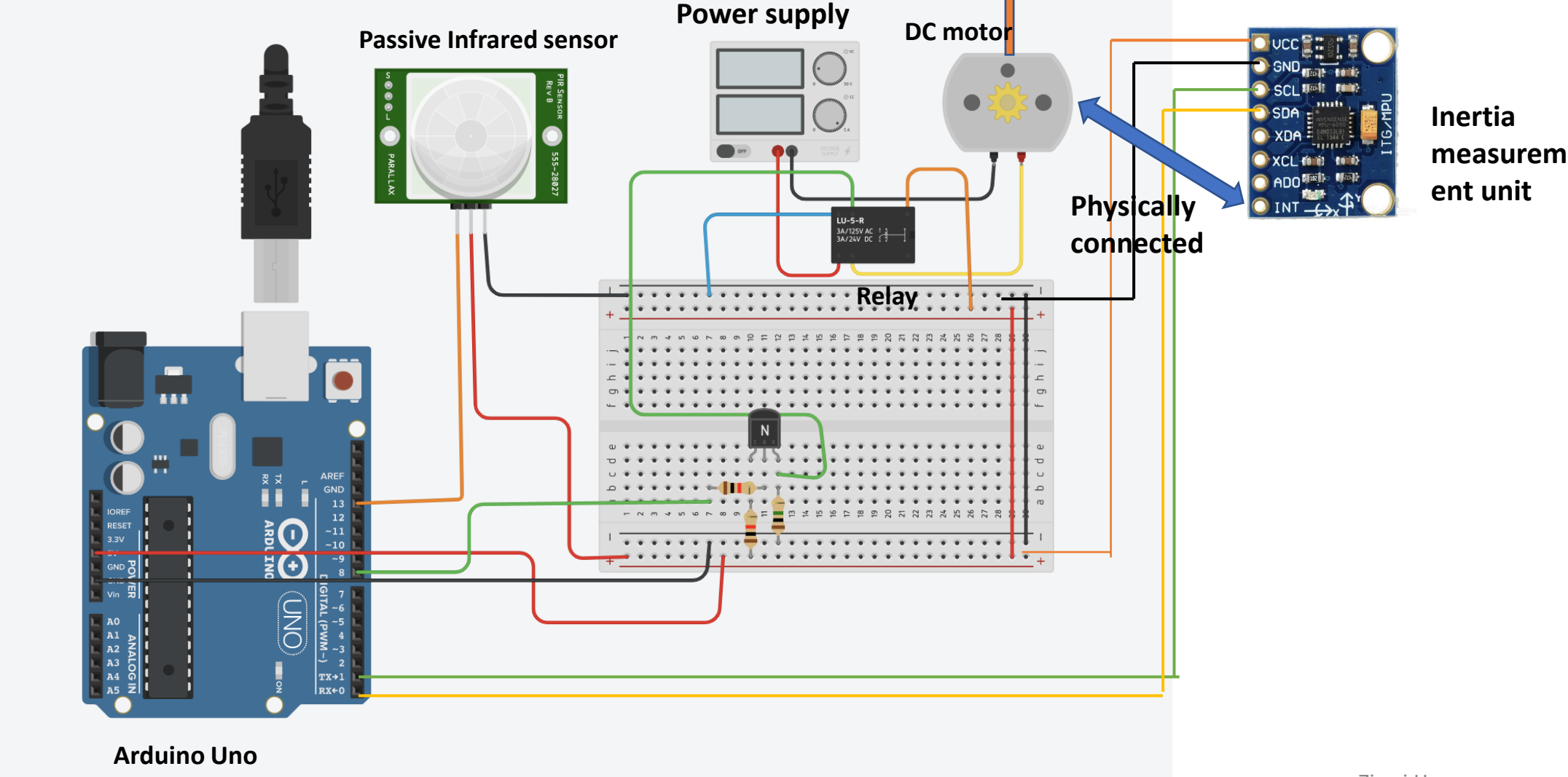

Schematic





Experiment Video
(ideal version)



Experimental Video (reality)

Thank you for
Watching